

## Limits/Alarms

### SERIES LV

Watlow's family of microprocessor-based limit controllers provides an economical solution for applications requiring temperature limit control. These limits are available in a broad range of packaging options, allowing users to select the best version for their individual application. The limits are available with an operator interface and can be ordered in 1/2 DIN-square panel mount or DIN-rail mount design configurations.

The LV limit family incorporates a microprocessor design platform. This design provides significant improvements in the performance, repeatability and accuracy offered by Watlow's current line of analog limit controllers.

The variable SERIES LV limit includes an operator interface for viewing and selecting the set point. A red, four-character seven segment LED displays the set point. The set point selection is made with a continuous turn rotary encoder. Operating range temperature values are customer definable in the product configuration part number.

The limit controllers are FM approved with special UL® approval for the open board potted versions. Watlow's limit controllers include industry leading service and support and are backed by a three-year warranty.

#### Applications

- Food preparation
- Industrial machinery
- Packaging
- Plastics processing

#### Features and Benefits

##### Adjustable set points

- Offer control flexibility

##### Four character LED display

- Improves set point selection accuracy



#### Multiple mounting options

- Minimize installation time

#### High or low limit with auto or manual reset

- Provides application flexibility

#### Fahrenheit or Celsius operation with indication

- Offers application flexibility

#### Sensor break protection

- Provides positive system shutdown

#### Agency approvals

- Meet certification requirements/compliance

#### Microprocessor based technology

- Ensures accurate repeatable control

#### Specifications

##### Limit Controller

- Microprocessor based, limit controller
- Nominal switching hysteresis, typically 1.7°C (3°F)
- High or low limit, factory selectable
- Latching output requires manual reset upon over or under temperature condition
- Manual or automatic reset on power loss, factory selectable
- Internal front panel or external customer supplied momentary reset switch
- Input filter time: 1 second

#### Operator Interface

- Four digit, seven segment LED displays, 7 mm (0.28 in.) high
- °C or °F indicator LED
- Alarm indicator LED
- Continuous turn, velocity sensitive rotary encoder for set point adjustment
- Front panel SET/RESET

#### Standard Conditions For Specifications

- Rated line voltage, 50 to 60Hz, 0 to 90 percent RH non-condensing, 15-minute warm-up
- Calibration ambient range: 25°C (77°F) ±3°C

#### Sensor Input

##### Thermocouple

- Grounded or ungrounded
- Type E, J, K, T thermocouple
- >10 MΩ input impedance
- 250 nV input referenced error per 1Ω source resistance

##### RTD

- 2-wire platinum, 100Ω
- DIN-curve (0.00385 curve)
- 125 μA nominal RTD excitation current

# Limits/Alarms

F.O.B.: Winona, Minnesota

## SERIES LV

### Specifications Cont.

#### Input Accuracy Span Range

Type E:	-200 to 800°C
	(-328 to 1472°F)
Type J:	0 to 750°C
	(32 to 1382°F)
Type K:	-200 to 1250°C
	(-328 to 2282°F)
Type T:	-200 to 350°C
	(-328 to 662°F)
RTD (DIN)	-200 to 800°C
	(-328 to 1472°F)

#### Thermocouple Input

- Calibration accuracy: ±1 percent of input accuracy span, ±1° at standard conditions and actual calibration ambient. Exception: Type T, ±2.4 percent of input accuracy span for -200 to 0°C (-328 to 32°F)
- Temperature stability: ±0.3° per degree change in ambient

#### RTD Input

- Calibration accuracy ±1 percent of input accuracy span ±1° at standard conditions and actual calibration ambient
- Temperature stability: ±0.2° per degree change in ambient

#### Allowable Operating Ranges

Type E:	-200 to 800°C
	(-328 to 1472°F)
Type J:	-210 to 1038°C
	(-346 to 1900°F)
Type K:	-270 to 1370°C
	(-454 to 2500°F)
Type T:	-270 to 400°C
	(-454 to 750°F)
RTD (DIN)	-200 to 800°C
	(-328 to 1472°F)

#### Electromechanical Relay, Form C

- Minimum load current: 100mA
- 8 A @ 240V~(ac) or 30V=(dc) maximum, resistive
- 250VA pilot duty, 120/240V~(ac) maximum, inductive
- Use RC suppression for inductive loads
- Electrical life 100,000 cycles at rated current

#### External Reset Switch

- Momentary, dry contact closure

#### Agency Approvals

- UL® 873 recognized temperature regulator
- UL® 197 reviewed for use in cooking appliances
- ANSI Z21.23 Gas appliance thermostat approval
- DIN 3440 - Temperature control and limiting devices for heat generating systems
- CSA C22.2#24 approved limit control (applied for)
- FM Class 3545 temperature limit switches (applied for)

#### Terminals

- 6.3 mm (0.25 in.) quick connect, push on terminal

#### Power

- 24V~(ac) +10 percent; -15 percent; 50/60Hz, ±5 percent
- 120V~(ac) +10 percent; -15 percent; 50/60Hz, ±5 percent
- 230 to 240V~(ac) +10 percent; -15 percent; 50/60Hz, ±5 percent
- 10VA maximum power consumption
- Data retention upon power failure via nonvolatile memory

#### Operating Environment

- 0 to 70°C (32 to 158°F)
- 0 to 90 percent RH, non-condensing
- Storage temperature: -40 to 85°C (-40 to 185°F)

#### Dimensions

- DIN-rail model can be DIN-rail or chassis mount  
DIN-rail spec DIN 50022, 35 mm x 7.5 mm (1.38 in. x 0.30 in.)

Style	Width	Height	Depth
DIN-rail	78.1 mm (3.08 in.)	112.3 mm (4.42 in.)	90.7 mm (3.57 in.)
Square 1/8 DIN-panel	72.4 mm (2.85 in.)	72.4 mm (2.85 in.)	Behind panel 51.7 mm (2.04 in.)

#### Ordering Information

To order, complete the model number on the right with the information below.

**SERIES LV =** Limit controller with eight amp relay output. Rotary set point, adjustment, four character, seven segment display, reset switch

**Power Supply** \_\_\_\_\_

C = 120V~(ac)  
E = 230 to 240V~(ac)  
G = 24V~(ac)

**Package** \_\_\_\_\_

1 = Panel mount square 1/8 DIN  
2 = DIN-rail mount

**Sensor Type and Scale** \_\_\_\_\_

H = T/C Type J Fahrenheit (-346 to 1900°F)  
J = T/C Type J Celsius (-210 to 1038°C)  
K = T/C Type K Fahrenheit (-454 to 2500°F)  
L = T/C Type K Celsius (-270 to 1370°C)  
M = T/C Type T Fahrenheit (-454 to 750°F)  
N = T/C Type T Celsius (-270 to 400°C)  
P = RTD Fahrenheit (-328 to 1472°F)  
R = RTD Celsius (-200 to 800°C)  
S = T/C Type E Fahrenheit (-328 to 1470°F)  
T = T/C Type E Celsius (-200 to 800°C)

**Limit Type** \_\_\_\_\_

U = High limit manual reset  
W = High limit auto reset  
Y = Low limit manual reset  
Z = Low limit auto reset

**Low Set Point Operating Range Value**® \_\_\_\_\_

**High Set Point Operating Range Value**® \_\_\_\_\_

**Overlay/Customs Options** \_\_\_\_\_

A = Standard

®A (-) is used in the left most digit of the set point operating ranges to indicate a negative temperature value

## Limits/Alarms

### SERIES LF

Watlow's family of microprocessor-based limit controllers provide an economical solution for applications requiring temperature limit control. These limits are available in a broad range of packaging options, allowing users to select the best version for their individual application. The controllers are available without an operator interface and can be ordered in square ½ DIN-panel mount, DIN-rail mount or open board design configurations.

The LF limit family incorporates a microprocessor design platform. This design provides significant improvements in the performance, repeatability and accuracy offered by Watlow's current line of analog basic temperature controllers.

The fixed SERIES LF limit offers fixed set points and is supplied without an operator interface. Operating set point temperature values are customer definable in the product configuration part number.

The LF limit controllers are FM approved with special UL® approval for the open board potted versions. Watlow's limit controllers include industry leading service and support and are backed by a three-year warranty.

#### Applications

- Food preparation
- Industrial machinery
- Packaging
- Plastics processing

#### Features and Benefits

##### Fixed set points

- Provide tamper-proof operation

##### Multiple mounting options

- Minimize installation time

##### High or low limit with auto or manual reset

- Provides application flexibility

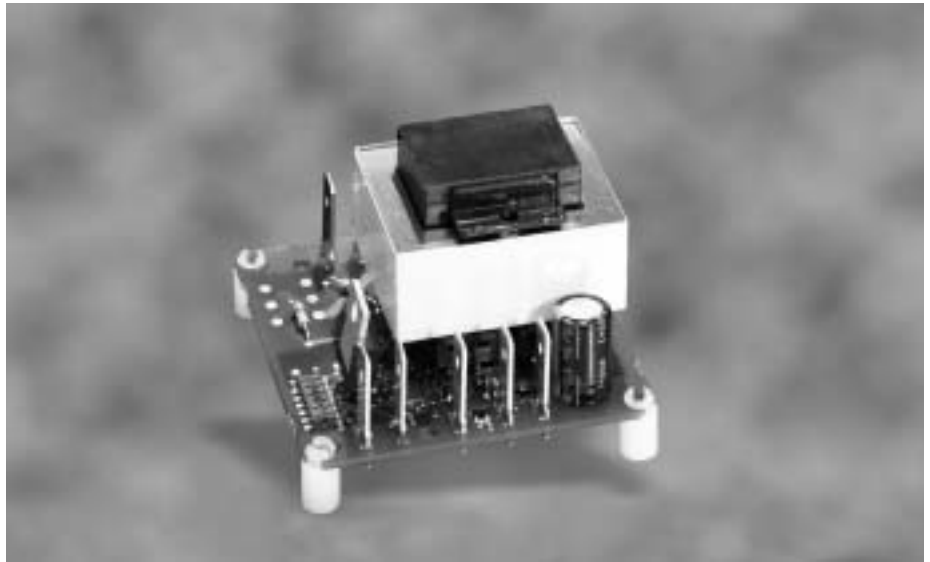

#### Fahrenheit or Celsius operation with indication

- Offers application flexibility

#### Sensor break protection

- Provides positive system shutdown

#### Agency approvals

- Meet certification requirements/compliance

#### Microprocessor based technology

- Ensures accurate repeatable control

#### Specifications

##### Limit Controller

- Microprocessor based, limit controller
- Nominal switching hysteresis, typically 1.7°C (3°F)
- High or low limit, factory selectable
- Latching output requires manual reset upon over or under temperature condition
- Manual or automatic reset on power loss, factory selectable
- External customer supplied momentary reset switch
- Input filter time: 1 second

##### Standard Conditions For Specifications

- Rated line voltage, 50 to 60Hz, 0 to 90 percent RH non-condensing, 15-minute warm-up
- Calibration ambient range: 25°C (77°F) ±3°C

#### Sensor Input Thermocouple

- Grounded or ungrounded
- Type E, J, K, T thermocouple
- >10 MΩ input impedance
- 250 nV input referenced error per 1Ω source resistance

#### RTD

- 2-wire platinum, 100Ω
- DIN-curve (0.00385 curve)
- 125 μA nominal RTD excitation current

#### Input Accuracy Span Range

Type E:	-200 to 800°C
	(-328 to 1472°F)
Type J:	0 to 750°C
	(32 to 1382°F)
Type K:	-200 to 1250°C
	(-328 to 2282°F)
Type T:	-200 to 350°C
	(-328 to 662°F)
RTD (DIN)	-200 to 800°C
	(-328 to 1472°F)

#### Thermocouple Input

- Calibration accuracy: ±1 percent of input accuracy span, ±1° at standard conditions and actual calibration ambient. Exception: Type T, ±2.4 percent of input accuracy span for -200 to 0°C (-328 to 32°F)
- Temperature stability: ±0.3° per degree change in ambient

# Limits/Alarms

F.O.B.: Winona, Minnesota

## SERIES LF

### Specifications Cont.

#### RTD Input

- Calibration accuracy ±1 percent of input accuracy span ±1° at standard conditions and actual calibration ambient
- Temperature stability: ±0.2° per degree change in ambient

#### Allowable Operating Ranges

Type E:	-200 to 800°C
	(-328 to 1472°F)
Type J:	-210 to 1038°C
	(-346 to 1900°F)
Type K:	-270 to 1370°C
	(-454 to 2500°F)
Type T:	-270 to 400°C
	(-454 to 750°F)
RTD (DIN)	-200 to 800°C
	(-328 to 1472°F)

#### Output Types

#### Electromechanical Relay, Form C

- Minimum load current: 100mA
- 8 A @ 240V~(ac) or 30V=(dc) maximum, resistive
- 250VA pilot duty, 120/240V~(ac) maximum, inductive
- Use RC suppression for inductive loads
- Electrical life 100,000 cycles at rated current

#### External Reset Switch

- Momentary, dry contact closure

#### Agency Approvals

#### SERIES LF (potted version only)

- UL® 991 recognized temperature limit for cooking industry
- CSA E60730-1, E60730-2-9 approved temperature regulator for cooking industry (applied for)

#### SERIES LF (including potted version)

- UL® 873 recognized temperature regulator
- UL® 197 reviewed for use in cooking appliances
- ANSI Z21.23 Gas appliance thermostat approval

- DIN 3440 - Temperature control and limiting devices for heat generating systems
- CSA C22.2#24 approved limit control (applied for)
- FM Class 3545 temperature limit switches (applied for)
- 10VA maximum power consumption
- Data retention upon power failure via nonvolatile memory

#### Operating Environment

- 0 to 70°C (32 to 158°F)
- 0 to 90 percent RH, non-condensing
- Storage temperature: -40 to 85°C (-40 to 185°F)

#### Dimensions

- DIN-rail model can be DIN-rail or chassis mount
- DIN-rail spec DIN 50022, 35 mm x 7.5 mm (1.38 in. x 0.30 in.)

#### Terminals

- 6.3 mm (0.25 in.) quick connect, push on terminal

#### Power

- 24V~(ac) +10 percent; -15 percent; 50/60Hz, ±5 percent
- 120V~(ac) +10 percent; -15 percent; 50/60Hz, ±5 percent
- 230 to 240V~(ac) +10 percent; -15 percent; 50/60Hz, ±5 percent

Style	Width	Height	Depth
Open Board	61.7 mm (2.43 in.)	61.7 mm (2.43 in.)	45.1 mm (1.78 in.)
Potted	70.1 mm (2.76 in.)	102.9 mm (4.05 in.)	46.6 mm (1.84 in.)
DIN-rail	78.1 mm (3.08 in.)	112.3 mm (4.42 in.)	90.7 mm (3.57 in.)
Square 1/8 DIN-panel	72.4 mm (2.85 in.)	72.4 mm (2.85 in.)	Behind panel 51.7 mm (2.04 in.)

#### Ordering Information

To order, complete the model number on the right with the information below.

**SERIES LF =** Limit controller with eight amp relay output. Fixed set point, no user interface

**Power Supply** \_\_\_\_\_

C = 120V~(ac)  
E = 230 to 240V~(ac)  
G = 24V~(ac)

**Package** \_\_\_\_\_

1 = Panel mount square 1/8 DIN  
2 = DIN-rail mount  
3 = Open board, non potted  
4 = Potted case

**Sensor Type and Scale** \_\_\_\_\_

H = T/C Type J Fahrenheit (-346 to 1900°F)  
J = T/C Type J Celsius (-210 to 1038°C)  
K = T/C Type K Fahrenheit (-454 to 2500°F)  
L = T/C Type K Celsius (-270 to 1370°C)  
M = T/C Type T Fahrenheit (-454 to 750°F)  
N = T/C Type T Celsius (-270 to 400°C)  
P = RTD Fahrenheit (-328 to 1472°F)  
R = RTD Celsius (-200 to 800°C)  
S = T/C Type E Fahrenheit (-328 to 1470°F)  
T = T/C Type E Celsius (-200 to 800°C)

**Limit Type** \_\_\_\_\_

U = High limit manual reset  
W = High limit auto reset  
Y = Low limit manual reset  
Z = Low limit auto reset

**Fixed Set Point Temperature Value<sup>ⓐ</sup>** \_\_\_\_\_

**Overlay/Customs Options** \_\_\_\_\_

A = Standard

LF \_\_\_\_\_ AAAA \_\_\_\_\_

<sup>ⓐ</sup>A (-) is used in the left most digit of the fixed set point indicates a negative temperature value

## Limits/Alarms

### SERIES SD\_L

The SERIES SD family of limit controllers has been designed with the same microprocessor-based technology as the SERIES SD PID family of temperature controllers. The limits come with FM (Factory Mutual) agency approval — the industry’s most recognized designation for insurance concerns. Limit controllers are typically added to thermal applications to monitor an over-temperature condition as a safety precaution. Limit controllers provide a redundant safety assurance to guard against instances where a high temperature runaway condition could result from a shorted input sensor, or from an output device that fails in a closed position.

Limits are recommended and are often required in applications where thermal runaway could result in costly operator safety concerns, product scrap, damage to capital equipment or a fire hazard.

The SD\_L limit family is also designed to work with Watlow’s HMI software WATVIEW.

#### Features and Benefits

##### FM approved

##### Watlow’s patented User Defined Menu System

- Allows the user to assign up to 20 parameters in the operations menu
- Improves operational efficiency

##### “Save and Restore” feature for user settings

- Allows the user to save individual or factory settings
- Eliminates the need to contact the OEM or factory to restore settings

##### WATVIEW HMI (Human Machine Interface)

- Permits operation, configuration and data logging via a standard Windows® PC

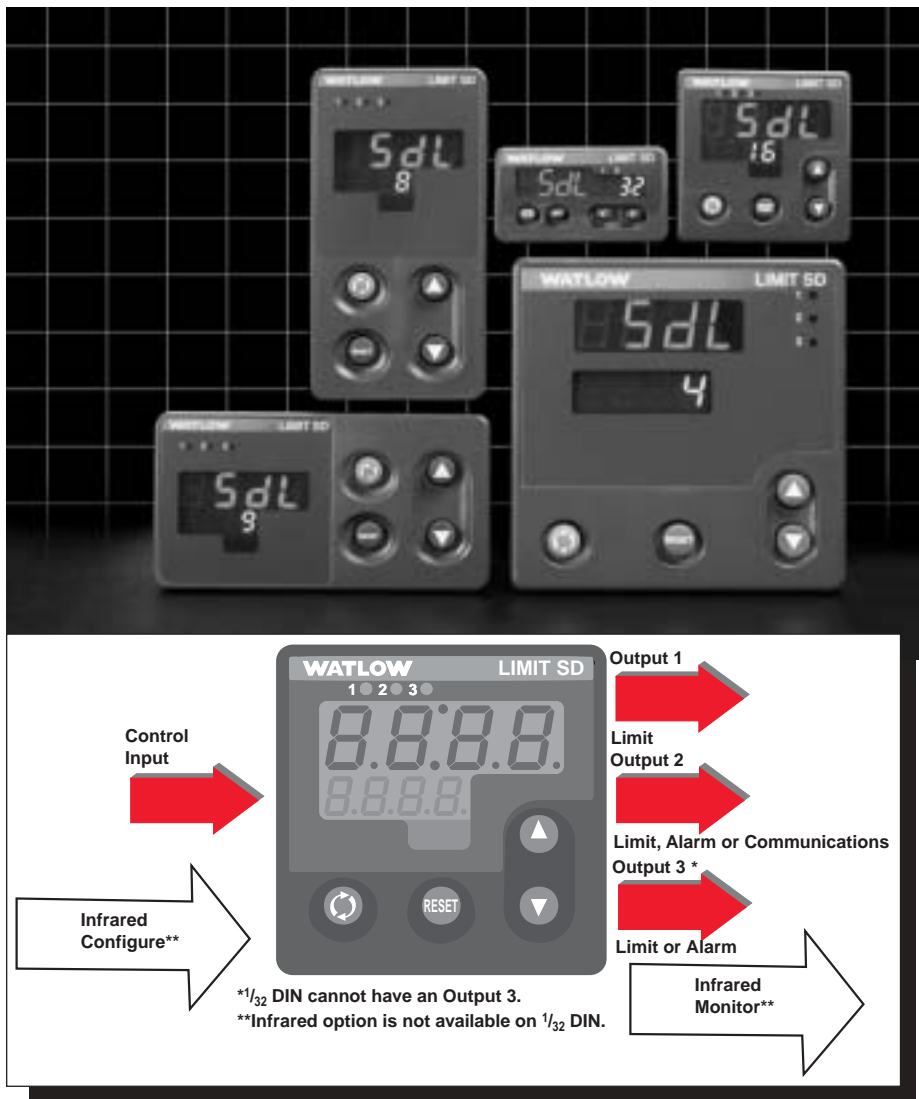

Single-Loop  
Limits/Alarms

##### Up to three outputs (two for 1/32 DIN)

- Results in application versatility

##### Dual display on all limit models

- Provides better recognition of process changes

##### Infrared communications (optional)

- Facilitates recipe management and data logging
- Allows easier controller setup, operation and monitoring

##### Watlow’s INFOSENSE™ sensor technology

- Thermal sensing technology improves sensor accuracy by a minimum of 50 percent

##### Specifications

##### Line Voltage/Power

- 100 to 240V~(ac), +10/-15 percent; (85-264V~[ac]) 50/60Hz, ±5 percent
- 24V≈(ac/dc), +10/-15 percent; 50/60Hz, ±5 percent
- 10VA maximum power consumption
- Data retention upon power failure via nonvolatile memory

# Limits/Alarms

## SERIES SD\_L

### Specifications Cont.

#### Environment

- 18 to 65°C (0 to 149°F) operating temperature
- 40 to 85°C (-40 to 185°F) storage temperature
- 0 to 90 percent RH, non-condensing

#### Accuracy

- Calibration accuracy and sensor conformity: ±0.1 percent of span, ±1°C @ the calibrated ambient temperature and rated line voltage
- Calibration ambient temperature = 25°C ±3°C (77°F ±5°F)
- Accuracy span: 540°C (1000°F) minimum
- Temperature stability: ±0.1°C/°C (±0.2°F/°F) rise in ambient maximum

#### Agency Approvals

- FM and NEMA 4X/IP65
- UL® 3121, C-UL®, CSA, CE for outputs 2 and 3
- NSF for Type J, K, T and E thermocouples

#### Controller

- Microprocessor based user-selectable control modes
- Single universal input, up to three outputs
- Control sampling rates: input = 6.5Hz, display = 10Hz, outputs = 6.5Hz

#### Operator Interface

- Dual 4 digit, 7 segment LED displays
- Advance, infinity and up down keys
- Optional IrDA infrared port (not available on 1/32 DIN)
- Isolated EIA-485 Modbus™ serial communications

### Wiring Termination -Touch Safe Terminals

- Input power and control outputs 12 to 22 AWG
- Sensor inputs and process outputs 20 to 28 AWG

### Universal Input

- Thermocouple, grounded or ungrounded sensors
- RTD 2- or 3-wire, platinum, 100Ω @ 0°C calibration to DIN-curve (0.00385 Ω/Ω/°C)
- Process, 0-20mA @ 100Ω, or 0-10V=(dc) @ 20kΩ input impedance; Scalable
- Inverse scaling
- >20MΩ input impedance
- Maximum of 20Ω source resistance

### Allowable Operating Range

Type J:	0 to 815°C (32 to 1500°F)
Type K:	-200 to 1370°C (-328 to 2500°F)
Type T:	-200 to 400°C (-328 to 750°F)
Type N:	0 to 1300°C (32 to 2372°F)
Type E:	-200 to 800°C (-328 to 1470°F)
Type C:	0 to 2315°C (32 to 4200°F)

### Dimensions

DIN Size	Behind Panel (max.)	Width	Height
1/32 DIN	97.8 mm (3.85 in.)	52.6 mm (2.07 in.)	29.7 mm (1.17 in.)
1/16 DIN	97.8 mm (3.85 in.)	52.1 mm (2.05 in.)	52.1 mm (2.05 in.)
1/8 DIN Vertical	97.8 mm (3.85 in.)	52.8 mm (2.08 in.)	99.8 mm (3.93 in.)
1/8 DIN Horizontal	97.8 mm (3.85 in.)	99.8 mm (3.93 in.)	52.8 mm (2.08 in.)
1/4 DIN	101.1 mm (3.98 in.)	99.8 mm (3.93 in.)	99.8 mm (3.93 in.)

Type D:	0 to 2315°C (32 to 4200°F)
Type PTII:	0 to 1395°C (32 to 2543°F)
Type R:	0 to 1760°C (32 to 3200°F)
Type S:	0 to 1760°C (32 to 3200°F)
Type B:	0 to 1816°C (32 to 3300°F)
RTD (DIN):	-200 to 800°C (-328 to 1472°F)
Process:-	1999 to 9999 units

### Control Outputs

#### Output 1

- Electromechanical relay. Form A, rated 2A @ 120V~(ac), or 240V~(ac) or 30V=(dc)

#### Output 2

- Electromechanical relay or E/A 485 comms, or switched DC, or SSR

#### Output 3

- (not available on 1/32 DIN) 5 amp Form C EM-relay, or SSR, universal process, or switched DC

## Limits/Alarms

### SERIES SD\_L

#### Typical Block Diagram

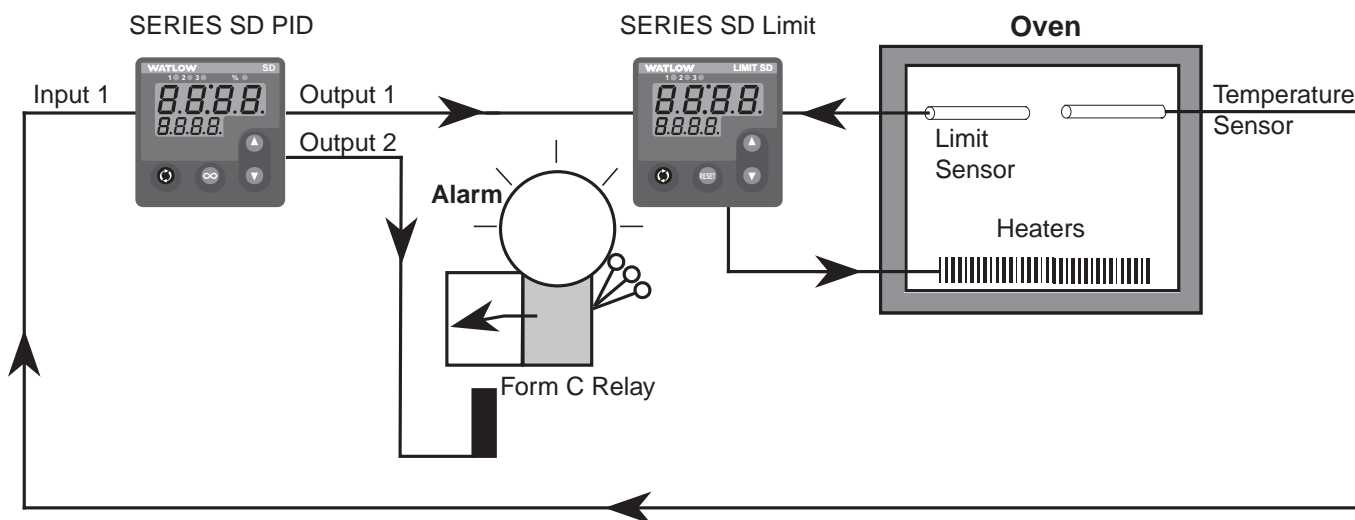

Note: Consult user manual for proper wiring.



#### Infrared Communications

The Infrared Data Communications (IDC) option is available on all SERIES SD controller models except the 1/2 DIN and can support complete SERIES SD parameter configuration and operation. The IDC option supports wireless communications with PDAs (personal digital assistants) or other devices equipped with

infrared communications that support the Infrared Data Association (IrDA) 1.0 Standard.

The actual user interface or configuration is dependent on the master device application software. A source for this software is Instant HMI from Software Horizons. For more information, visit [www.instanthmi.com/watlow](http://www.instanthmi.com/watlow).

Advantages of IDC include automated logging of key process variables, increased accuracy and ease of use for recipe or configuration setups. Infrared data communications enhances controller data exchange in physically restricting environments (such as semiconductor clean rooms, governmental radio-active test labs or those hard to reach areas) and reduces the use of paper to record instrument information as well as human transposition errors.



#### WATVIEW HMI

WATVIEW, Watlow's Windows® based HMI (Human Machine Interface) software, supports the SERIES SD controllers. The software can be used to setup, monitor and edit the values of controller parameters, to monitor and manage alarms and to log and graph process data.

## SERIES SD\_L

### Ordering Information

To order, complete the model number on the right with the information below.

**SERIES SD\_L** = Temperature limit controllers<sup>®</sup>

**DIN Sizes**

- 3 = 1/32 DIN
- 6 = 1/16 DIN
- 8 = 1/8 DIN Vertical
- 9 = 1/8 DIN Horizontal
- 4 = 1/4 DIN

**Control Type**

- L = Limit Control Dual Display

**Power Supply**

- H = 100 to 240V $\approx$ (ac/dc)
- L = 24 to 28V $\approx$ (ac/dc)

**Output 1**

- J = Mechanical relay, Form A, 2A

**Output 2**

- A = None
- C = Switched dc
- K = SSR, Form A, 0.5A
- J = Mechanical relay, Form A, 2A
- U = EIA-485 Modbus™ communications

**Output 3 (Not available on 1/32 DIN)**

- A = None
- C = Switched dc/open collector
- K = SSR, Form A, 0.5A
- F = Universal process
- E = Mechanical relay, Form C, 5A

**Infrared Comms Options (IrDA)**

- A = None (Default selection on 1/32 DIN)
- R = IrDA ready (Not available on 1/32 DIN)

**Display Colors and Custom Options**

- RG = Red Green (Dual display units)
- RR = Red Red (Not available on 1/32 DIN Dual Display)
- XX = Custom options, special overlays, etc.

<sup>®</sup> Only available in dual displays, red/green.

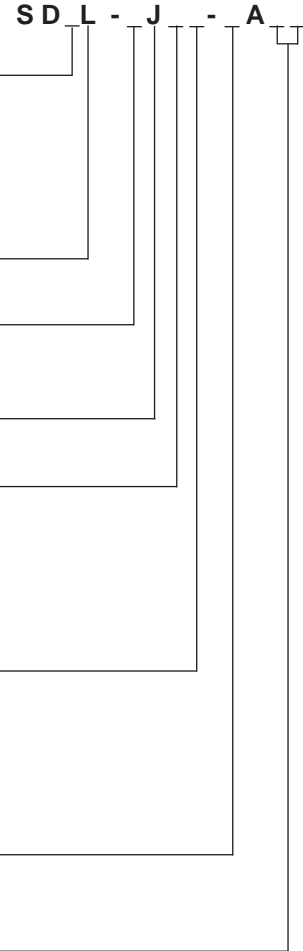

## Limits/Alarms

### SERIES SD6L\_D

Watlow SERIES SD6L\_D offers excellent Limit control and application flexibility in a 1/16<sup>th</sup> DIN panel mount package. The SERIES SD6L\_D controller has been successfully tested for use with both ODVA and Semi-conductor SIG standards for DeviceNet™ on CAN networks and comes with FM Approval.

The SD6L\_D single channel controller includes a universal sensor input with two outputs. Output 1 comes preconfigured with a Mechanical Relay dedicated for safety shutdown purposes to meet FM requirements. Output 2 can be configured as an Alarm. The DeviceNet™ communications interface is supplied with either a five pin circular DIN connector for Semiconductor SIG specific applications, or with a five position removable screw terminal connector for traditional market applications. Additional features of the SD6L\_D family of controllers include Watlow's INOFSENSE™ sensor technology, a user definable menu system as well as a Save and Restore feature that allows the restoration of factory and user defined parameter values.

Watlow SD6L\_D DeviceNet™ Limit controllers include a three year warranty and are FM approved with IP65/NEMA 4, CE and NSF ratings. When not used as a Limit device the following agency approvals apply: UL®, C-UL® listed, and CSA ratings.

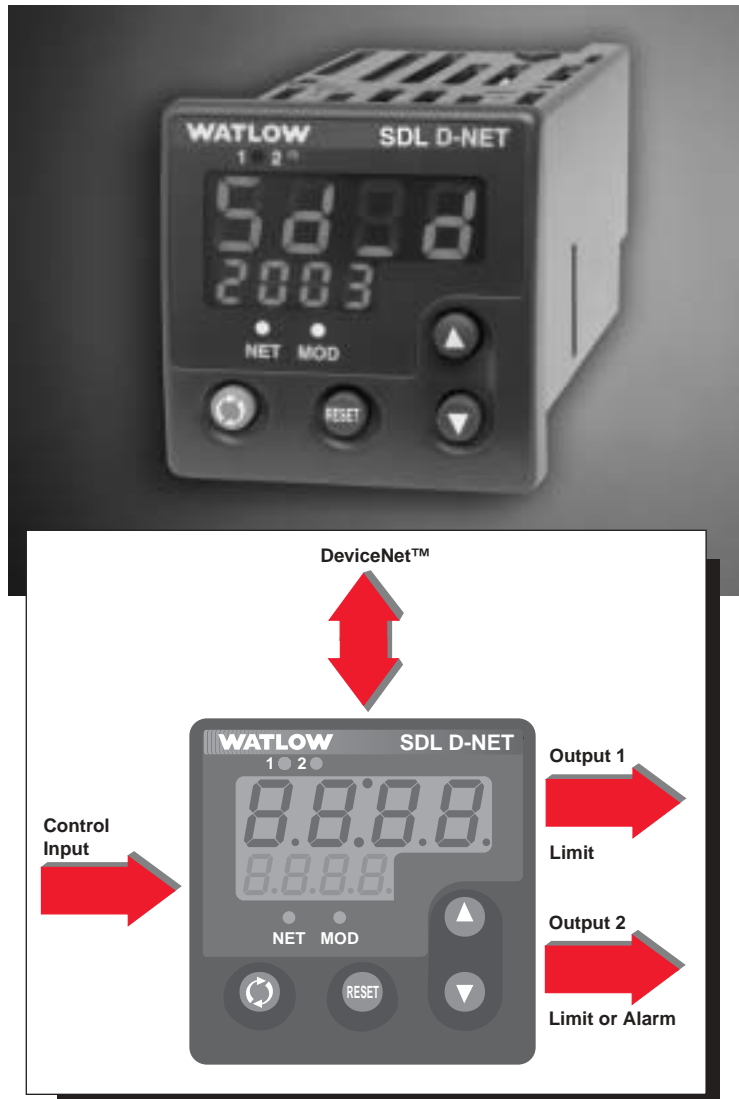

Single-Loop  
Limits/Alarms

#### Features and Benefits

##### Variable burst fire

- Prolongs heater life

##### Ordering Options including DeviceNet™ on CAN or SEMI-SIG-ODVA protocols

- Provides DeviceNet™ on CAN for Semiconductor applications
- DeviceNet™ on CAN for the packaging or general industrial markets

#### Specifications

##### Line Voltage/Power

- 100 to 240V~(ac), +10/-15 percent; (85-264V~[ac]) 50/60Hz, ±5 percent
- 24V≈(ac/dc), +10/-15 percent; 50/60Hz, ±5 percent
- 10VA maximum power consumption
- Data retention upon power failure via nonvolatile memory

DeviceNet™ is a trademark of the Open DeviceNet Vendors Association.  
UL® and C-UL® are registered trademarks of Underwriters Laboratories, Inc.

# Limits/Alarms

F.O.B.: Winona, Minnesota

## SERIES SD6L\_D

### Specifications Cont.

#### Environment

- 18 to 65°C (0 to 149°F) operating temperature
- 40 to 85°C (-40 to 185°F) storage temperature
- 0 to 90 percent RH, non-condensing

#### Accuracy

- Calibration accuracy and sensor conformity: ±0.1 percent of span, ±1°C @ the calibrated ambient temperature and rated line voltage
- Calibration ambient temperature = 25°C ±3°C (77°F ±5°F)
- Accuracy span: 540°C (1000°F) minimum
- Temperature stability: ±0.1°C/°C (±0.2°F/°F) rise in ambient maximum

#### Agency Approvals

- FM, IP65/NEMA 4X and NSF-2
- UL® 3121, C-UL®, CSA, CE,

#### Controller

- Microprocessor based user-selectable control modes
- Single universal input, up to three outputs
- Control sampling rates: Input = 6.5Hz, Display = 10Hz and Outputs = 6.5Hz

#### Operator Interface

- Dual 4 digit, 7 segment LED displays
- DeviceNet™ on CAN or
- Semi-SIG-ODVA

#### Allowable Operating Range

Type J: 0 to 815°C  
(32 to 1500°F)  
Type K: -200 to 1370°C  
(-328 to 2500°F)

Type T: -200 to 400°C  
(-328 to 750°F)

Type N: 0 to 1300°C  
(32 to 2372°F)

Type E: -200 to 800°C  
(-328 to 1470°F)

Type C: 0 to 2315°C  
(32 to 4200°F)

Type D: 0 to 2315°C  
(32 to 4200°F)

Type PTII: 0 to 1395°C  
(32 to 2543°F)

Type R: 0 to 1760°C  
(32 to 3200°F)

Type S: 0 to 1760°C  
(32 to 3200°F)

Type B: 0 to 1816°C  
(32 to 3300°F)

RTD (DIN): -200 to 800°C  
(-328 to 1472°F)

Process: -1999 to 9999 units

#### Control Outputs

- Electromechanical relay. Form A, rated 2A @ 120V~(ac), 2A @ 240V~(ac) or 2A @ 30V=(dc)

- Switched dc non-isolated minimum turn on voltage of 6V=(dc) into a minimum 500Ω load with a maximum on voltage of not greater than 12V=(dc) into an infinite load. Maximum switched dc power supply current available for up to two outputs is 60mA
- Solid-state relay, Form A, 0.5A @ 24V~(ac) minimum, 264V~(ac) maximum, opto-isolated, without contact suppression
- Electromechanical relay. Form C, rated 5A @ 120V~(ac), 5A @ 240V~(ac) or 5A @ 30V=(dc)
- Open collector 42V=(dc) @ 250mA maximum

#### Dimensions

- 1/16 DIN Size
- 97.8 mm (3.85 in.) behind panel maximum
- Width 52.1 mm (2.05 in.)
- Height 52.1 mm (2.05 in.)

#### Ordering Information

To order, complete the model number on the right with the information below.

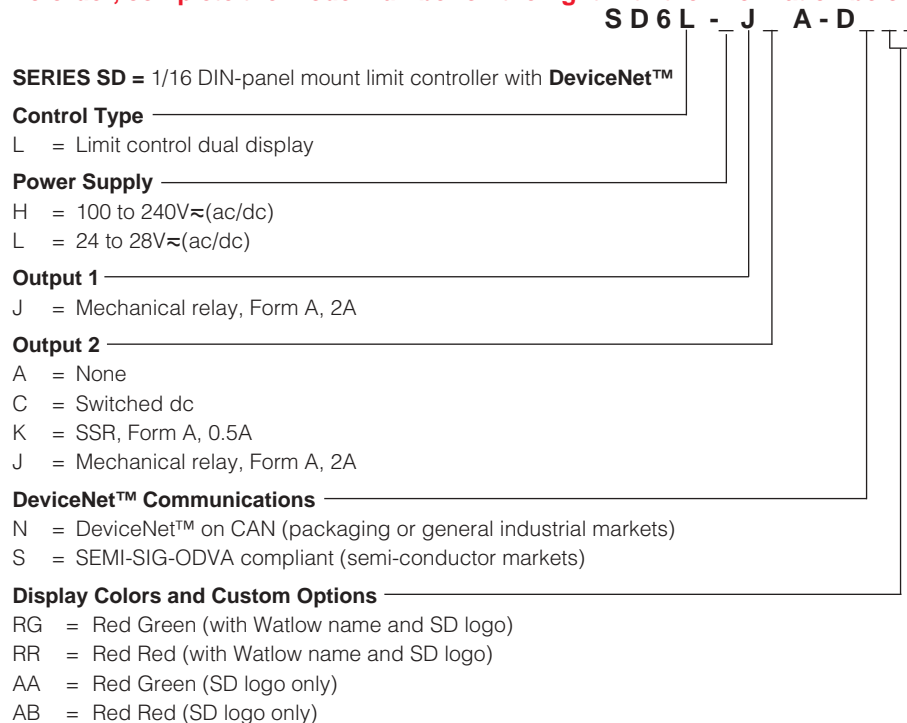

## Limits/Alarms

### SERIES 97

Watlow's SERIES 97 is a micro-processor-based controller with a single input, second auxiliary input and four outputs. Input 1 is used to measure temperature from a sensor. Input 2 can be utilized as a remote reset switch or a hardware lockout switch. With up to four outputs, the controller is versatile in handling applications that require a high/low limit, alarms, retransmit and communications. The control is so user friendly it can be set up to display safety and limit messages created by the end user to meet the exact application need.

The SERIES 97 limit controller is added to thermal applications to limit over-temperature conditions. The SERIES 97 limit controller provides safety assurance against instances where a high temperature runaway condition could occur from a shorted input sensor or an output device that could fail in a closed position.

The SERIES 97 is recommended for any application where thermal runaway could result in large product scrap costs, affect operator safety, cause damage to equipment or create a fire hazard.

The SERIES 97 is manufactured by ISO 9001 registered Watlow Winona and reliably backed up by a three-year warranty.

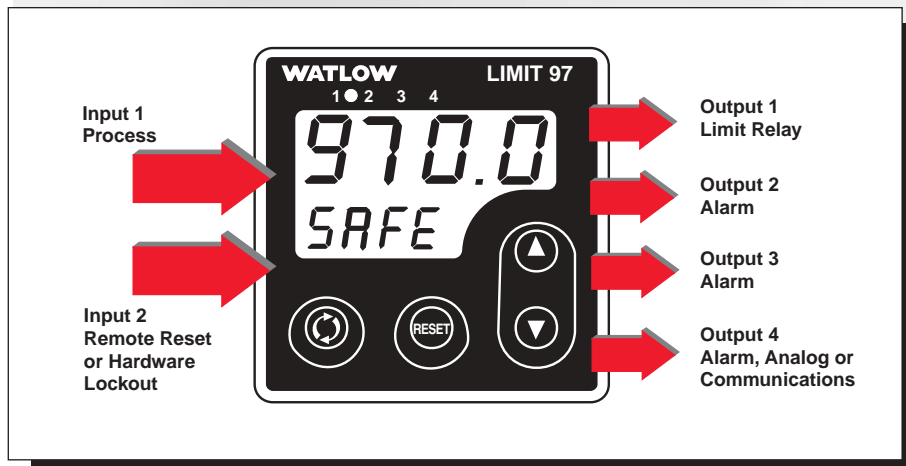

Single-Loop  
Limits/Alarms

#### Features and Benefits

##### Programmable messages (Patented)

- Controller can be set up to display user programmed limit message

##### NEMA 4X (IP65)

- Water and corrosion resistant; front panel can be washed down

##### Microprocessor-based

- Accurate set point settings and quick output response

##### Second auxiliary input

- Remote reset capability

#### Four outputs

- Handles high/low limit, alarms, communication and retransmit requirements

##### Software and hardware lockouts

- High security
- **Three-year warranty** provides Control Confidence®

##### Applications

- Furnace and ovens
- Environmental chambers
- Semiconductor
- Food processing
- Boilers
- Laboratory equipment

# Limits/Alarms

## SERIES 97

### Specifications

#### Controller

- Microprocessor-based
- Universal input 1, auxiliary input 2, 4 outputs
- Input sample period; Single input 10Hz (100 msec), dual input 5Hz (200 msec) digital filter adjustable
- Display update; 2Hz (500 msec), time filter adjustable
- Input/Output/Communication isolation
- Displayed in °C, °F

#### Operator Interface

- Dual 4-digit LED displays: upper 10.2 mm (0.4 in.), lower 6.2 mm (0.244 in.)
- Advance, Up Arrow, Down Arrow, Reset tactile keys

#### Standard Conditions For Specifications

- Ambient temperature 25°C (77°F) ±3°C, rated line voltage, 50 to 60Hz, 0 to 90 percent RH non-condensing, 15 minute warm-up

#### Universal Input 1

##### Thermocouple

- Type J, K, T, N, C (W5), E, PTII, D (W3), B, R, S thermocouple types
- >20MΩ input impedance
- Maximum 20Ω source resistance
- 30mA open detection bias

##### RTD

- 2- or 3-wire platinum, 100Ω
- JIS and DIN-curves
- Whole or tenth degree indication
- 150μA nominal RTD excitation current

#### Input 2

##### Event Input

- Contact or voltage
- 20KΩ input impedance

- Voltage input: event high state 3 to 36V=(dc), event low state 0 to 2V=(dc)
- Resistance/contact input: event high state > 23kΩ, event low state 0 to 2kΩ

#### Output Types

##### Open Collector/Switched DC

- Open collector configuration: Maximum voltage 42V=(dc) Maximum current 200mA Maximum "on" resistance 1.1Ω Maximum off state leakage current 100μA
- Switched dc configuration: Switched dc supply voltage 22 to 28V=(dc) dc supply current limited to 30mA

##### Solid State Relay

- Optically isolated
- Zero cross switched
- Without contact suppression
- Minimum load current 0.5mA rms
- Maximum current 0.5A rms at 20 to 280V~(ac)
- Maximum off state leakage current 10μA rms
- For resistive loads only, must use RC suppression for inductive loads

##### Electromechanical Relay

- Form C contact configuration
- Minimum load current 10mA @ 5V=(dc)
- Rated resistive and inductive loads: 2A @ 250V~(ac) or 30V=(dc) maximum
- Electrical life 100,000 cycles at rated current
- For resistive loads only, must use RC suppression for inductive loads

#### Retransmit

- Range selectable: 0-20mA, 4-20mA, 0-5V=(dc), 1-5V=(dc), 0-10V=(dc)
- 0 to 10V=(dc) voltage output into a 1,000Ω minimum load resistance

- 0 to 20mA current output into an 800Ω maximum load resistance
- Resolution: V=(dc) ranges = 2.5mV nominal mA ranges = 5μA nominal
- Calibration accuracy: V=(dc) ranges = ±15mV mA ranges = ±30μA
- Temperature stability 100ppm/°C

#### Communications

- EIA/TIA-485, EIA/TIA-232
- Opto-isolated
- Modbus™ RTU protocol
- 1200, 2400, 4800, 9600, 19200 baud rates
- 32 maximum units can be connected (With additional 485 repeater hardware, up to 247 units may be connected)

#### Accuracy

- Input ranges
  - Type J: 0 to 750°C (32 to 1382°F)
  - Type K: -200 to 1250°C (-328 to 2282°F)
  - Type T: -200 to 350°C (-328 to 662°F)
  - Type N: 0 to 1250°C (32 to 2282°F)
  - Type E: -200 to 900°C (-328 to 1470°F)
  - Type C(W5): 0 to 2315°C (32 to 4200°F)
  - Type D(W3): 0 to 2315°C (32 to 4200°F)
  - Type PTII: 0 to 1393°C (32 to 2540°F)
  - Type R: 0 to 1450°C (32 to 2642°F)
  - Type S: 0 to 1450°C (32 to 2642°F)
  - Type B: 870 to 1700°C (1598 to 3092°F)
  - DIN: -200 to 800°C (-328 to 1472°F)
  - JIS: -200 to 630°C (-328 to 1166°F)

Modbus™ is a trademark of AEG Schneider Automation.

## Limits/Alarms

### SERIES 97

#### Specifications Cont.

##### Thermocouple Inputs

- Calibration accuracy  $\pm 0.1$  percent of span  $\pm 1^\circ\text{C}$  at standard conditions  
 Exceptions:  
 Type T: 0.12 percent of span for  $-200^\circ\text{C}$  to  $-50^\circ\text{C}$  ( $-328^\circ\text{F}$  to  $-58^\circ\text{F}$ )  
 Types R and S: 0.15 percent of span for  $0^\circ\text{C}$  to  $100^\circ\text{C}$  ( $32^\circ\text{F}$  to  $212^\circ\text{F}$ )  
 Types B: 0.24 percent of span for  $870^\circ\text{C}$  to  $1700^\circ\text{C}$  ( $1598^\circ\text{F}$  to  $3092^\circ\text{F}$ )
- Accuracy span:  $540^\circ\text{C}$  ( $1000^\circ\text{F}$ ) minimum
- Temperature stability:  $\pm 0.1^\circ$  per degree change in ambient

##### RTD Inputs

- Calibration accuracy  $\pm 0.1$  percent of span  $\pm 1^\circ\text{C}$  at standard conditions
- Accuracy span:  $540^\circ\text{C}$  ( $1000^\circ\text{F}$ ) minimum
- Temperature stability:  $\pm 0.05^\circ$  per degree change in ambient

##### Agency Approvals

- FM Class 3545, File # J.I. 1B5A6.AF
- NEMA 4X, IP65
- CE 89/336/EEC, electromagnetic compatibility directive  
 CE 73/23/EEC, low-voltage directive

##### Functionality Matrix

	Universal Input	Event	High/Low Limit	High/Low Alarm	Retransmit	232 485 Comm
Input 1						
Input 2						
Output 1						
Output 2						
Output 3						
Output 4						

Note: These specifications are subject to change without prior notice.

#### Terminals

- Touch safe
- 22 to 12 AWG

#### Power

- 100-240V~(ac) +10 percent, -15 percent; 50/60Hz,  $\pm 5$  percent
- 24-28V~(ac) or V=(dc) +10 percent, -15 percent; 50/60Hz,  $\pm 5$  percent
- 7.0VA maximum power consumption
- Data retention upon power failure via nonvolatile memory

#### Operating Environment

- 0 to  $65^\circ\text{C}$  (32 to  $149^\circ\text{F}$ )
- 0 to 90 percent RH, non-condensing
- Storage temperature:  $-40$  to  $85^\circ\text{C}$  ( $-40$  to  $185^\circ\text{F}$ )

#### Dimensions

- Width 52 mm (2.05 in.)
- Height 52 mm (2.05 in.)
- Length 107 mm (4.2 in.)
- Depth behind panel surface 98.4 mm (3.875 in.)
- Approximate controller weight 0.2 kg (0.4 lbs)

#### Allowable Operating Ranges

Type J:	1.0	0 to $815^\circ\text{C}$ (32 to $1500^\circ\text{F}$ )
	0.1	0 to $815^\circ\text{C}$ (32 to $1500^\circ\text{F}$ )
Type K:	1.0	$-270$ to $1370^\circ\text{C}$ ( $-454$ to $2500^\circ\text{F}$ )
	0.1	$-200$ to $1000^\circ\text{C}$ ( $-328$ to $1832^\circ\text{F}$ )
Type T:	1.0	$-270$ to $400^\circ\text{C}$ ( $-454$ to $750^\circ\text{F}$ )
	0.1	$-200$ to $400^\circ\text{C}$ ( $-328$ to $750^\circ\text{F}$ )
Type N:	1.0	0 to $1300^\circ\text{C}$ (32 to $2372^\circ\text{F}$ )
	0.1	0 to $1000^\circ\text{C}$ (32 to $1832^\circ\text{F}$ )
Type E:	1.0	$-270$ to $1800^\circ\text{C}$ ( $-454$ to $3272^\circ\text{F}$ )
	0.1	$-110$ to $800^\circ\text{C}$ ( $-166$ to $1472^\circ\text{F}$ )
Type C:	1.0	0 to $2315^\circ\text{C}$ (32 to $4200^\circ\text{F}$ )
	0.1	0 to $1000^\circ\text{C}$ (32 to $1832^\circ\text{F}$ )
Type D:	1.0	0 to $2315^\circ\text{C}$ (32 to $4200^\circ\text{F}$ )
	0.1	0 to $1000^\circ\text{C}$ (32 to $1832^\circ\text{F}$ )
Type PTII:	1.0	0 to $1395^\circ\text{C}$ (32 to $2543^\circ\text{F}$ )
	0.1	0 to $1000^\circ\text{C}$ (32 to $1832^\circ\text{F}$ )
Type R:	1.0	0 to $1760^\circ\text{C}$ (32 to $3200^\circ\text{F}$ )
Type S:	1.0	0 to $1760^\circ\text{C}$ (32 to $3200^\circ\text{F}$ )
Type B:	1.0	0 to $1816^\circ\text{C}$ (32 to $3300^\circ\text{F}$ )
DIN	1.0	$-200$ to $800^\circ\text{C}$ ( $-328$ to $1472^\circ\text{F}$ )
	0.1	$-200$ to $800^\circ\text{C}$ ( $-328$ to $1472^\circ\text{F}$ )
JIS	1.0	$-200$ to $630^\circ\text{C}$ ( $-328$ to $1166^\circ\text{F}$ )
	0.1	$-200$ to $630^\circ\text{C}$ ( $-328$ to $1166^\circ\text{F}$ )

# Limits/Alarms

F.O.B.: Winona, Minnesota

## SERIES 97

### Ordering Information

To order, complete the model number on the right with the information below.

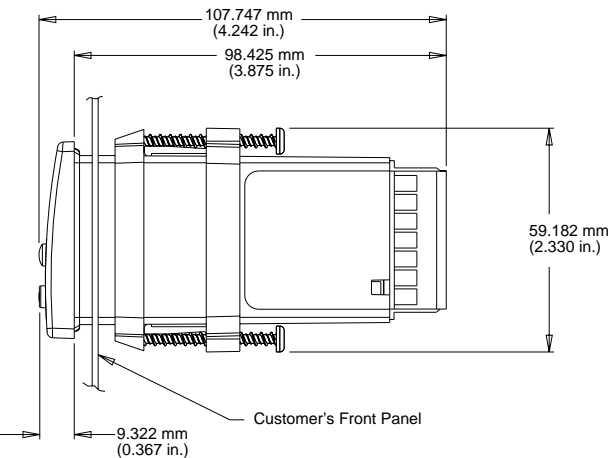
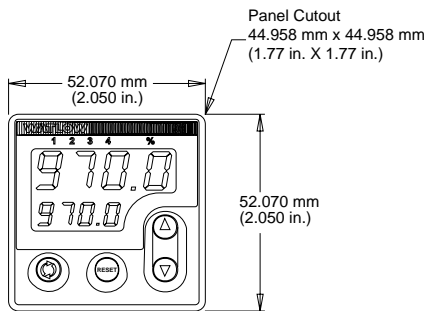
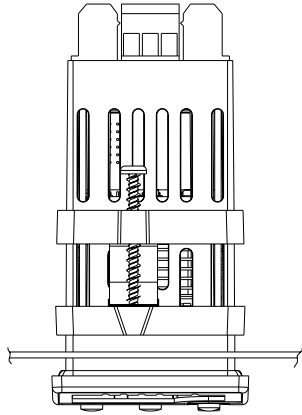

**SERIES 97** = Microprocessor-based 1/6 DIN with universal input 1, thermocouple and RTD. Options include: software, power supply, input 2, four outputs and display color

#### Power Supply

- A = 100-240V $\approx$ (ac/dc)
- B = 24-28V $\approx$ (ac/dc)

#### Auxiliary Input 2

- 0 = None
- 1 = Event input

#### Limit Output 1

- D = Electromechanical relay, Form C, 2A, without RC suppression

#### Alarm Output 2

- A = None
- C = Switched dc output/open collector
- D = Electromechanical relay, Form C, 2A, without RC suppression
- K = 0.5A Solid State Relay without RC suppression

#### Alarm Output 3

- A = None
- D = Electromechanical relay, Form C, 2A, without RC suppression

#### Auxiliary Output 4

- A = None
- D = Electromechanical relay, Form C, 2A, without RC suppression
- R = 232 Communications
- U = 485 Communications
- M = Universal Retransmit, range selectable: 0-20mA, 4-20mA, 0-5V $\approx$ (dc), 1-5V $\approx$ (dc), 0-10V $\approx$ (dc)

#### Software/Preset Parameters

- 00 = Standard software

#### Display/Overlay

- Upper/Lower
- RR = Red/Red display
- RG = Red/Green display
- GR = Green/Red display
- GG = Green/Green display

