

# Thermostats and Accessories

## Thermostats and Accessories

SERIES EHG® .....	641
SERIES EHG SL10 .....	643
ST10 and ST207 .....	647
Bulb and Capillary .....	649
Low Liquid Level Sensors.....	653
Protective Wells .....	654





# Thermostats and Accessories

## SERIES EHG®

Many applications requiring a fixed temperature set point have relied on mechanical thermostat devices (thermostats) for thermal control. But, thermostats are inadequate for many applications because of the long-term reliability issues such as 100,000 cycle rating and poor temperature control.

The SERIES EHG® thermal solution includes a compact temperature control, thermocouple sensor and power switching device that are integrated into the heater's power cord. The SERIES EHG reduces system costs and substantially extends the life over conventional thermostat solutions.

The evolution of miniature microprocessor technology and Watlow switching technology allowed the development of a small versatile temperature control and thermocouple sensor that can be integrated with Watlow silicone rubber heater products. This device senses the temperature via input from a thermocouple strategically placed on the heater mat. The microprocessor is programmed prior to shipment with the customer's application specific set point. This results in quick delivery of a custom integrated system.

The small mass of the thermocouple provides superior response to changes in process temperature and allows for higher watt density silicone rubber heater designs. Depending on the specific application, Watlow's power switching design can extend life up to 40 times greater than thermostats. These features result in an integrated custom set point temperature control product with superior life span, faster heat-up rates and improved accuracy. The SERIES EHG system has been tested to over four million cycles at rated amperage.

### Features and Benefits

#### Long operational life

- Improves system reliability

#### Tight temperature control

- Assures process accuracy

#### Small sensor footprint

- Fits with almost any heater
- Responds quickly to temperature changes
- Controls high watt densities in low mass applications

#### Reduced system cost

- A single EHG control can be configured with multiple heaters to reduce system cost

#### Pre-wired, in line control

- Simplifies installation
- Two wire power connection



#### Durable housing with built-in strain relief

- Protects electronics
- Low risk of mechanical damage

#### Manufactured with proven Watlow components

- Assures reliable system performance

#### Applications

- Aerospace composite repair
- Foodservice equipment
- Freeze protection
- Life sciences
- Semiconductor
- Telecommunications

# Thermostats and Accessories

## SERIES EHG

### Technical Information

#### Specifications

##### Operational

- SERIES EHG silicone rubber heater UL® recognized to 428°F (220°C) operating temperature
- Factory programmed fixed set point
- On-off control with 6°F (3°C) switching hysteresis
- Temperature band LED indicator ON between -68 and +68°F (-20 and +20°C) of set point

##### Electrical

- Voltage rating: 120 or 240V~(ac) – 30/+10%, 50/60Hz
- Silicone rubber heater watt densities up to 80 W/in<sup>2</sup> (12.5 W/cm<sup>2</sup>) dependent on application temperature
- SERIES EHG system UL® recognized to 10A max.

##### Sensor

- Type K thermocouple

##### Mechanical

- Control dimensions 3.75 in. (95 mm) long by 1.75 in. (45 mm) diameter
- Heater per silicone rubber heater specifications

##### Agencies

- Silicone rubber heater: UL® recognized File #E52951
- SERIES EHG control: TUV File DE 3-3068 to EN 61010-1:2001, UL® File E43684 to UL® 873 temperature indicating and regulating equipment

##### Environmental

- Control operating temperature range 32 to 128°F (0 to 70°C)
- Control storage temperature range -40 to 158°F (-40 to 70°C)

Contact your Watlow representative for custom configurations.

### SERIES EHG Versus Thermostat (typical application)

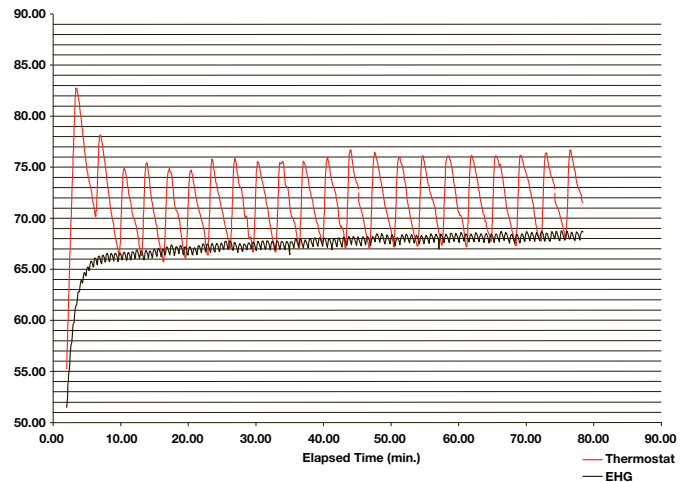

### Dimensions

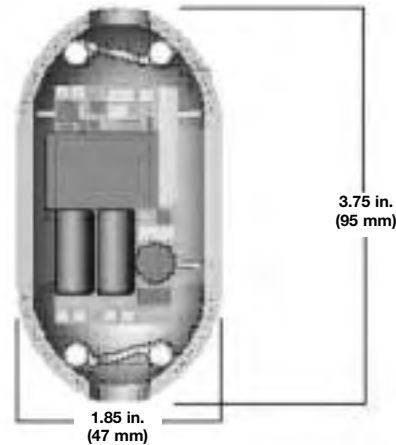

### Integrated SERIES EHG System Versus Integrated Thermostat System

	Integrated EHG System	Integrated Thermostat System	SERIES EHG Benefit
Life comparison at rated amperage 10A load	Tested to greater than 4,000,000 cycles with	Rated 100,000 cycles  high reliability in application	Longer product life of SERIES EHG system and
Switch hysteresis	6°F (3°C)	15°F (8°C)	SERIES EHG system will provide superior process control
Improved response time reduces overshoot on start-up	6°F (3°C) typical	25°F (14°C) typical	SERIES EHG system will respond changes in temperature faster than thermostat
Warranty	2 years on material and workmanship	1 year on material and workmanship	Warranty can be extended because of superior SERIES EHG life
Zero Cross Switching	SERIES EHG has zero cross switching	Random switching during sign wave cycle	Reduces possibility of electrical mechanical interference (EMI)

# Thermostats and Accessories

## SERIES EHG® SL10

The EHG® SL10 is a key component in a powerful system that integrates a heater, an adjustable set point temperature controller, high/low temperature alert, power switching device and a high temperature safety limit. This agency recognized controller/safety limit meets UL® 1998 and CE 60730 requirements. The optional display/communications module can be easily upgraded and added in the field to provide digital display indication, adjustment of set point, RS485 Modbus® communications and other Human Machine Interface (HMI) features. This system allows you to purchase only what is needed for your application.

The easy to install, compact design, inherent reliability and integrated limit functions make this controller a tremendous value. The controller is designed for easy integration with Watlow® heaters simplifying engineering, reducing component count on new equipment and decreasing cost of ownership. For original equipment manufacturers (OEMs), CE, Semi-S2 compliance and UL® recognition will reduce time and costs necessary for global agency testing and validation.

### Features and Benefits

#### Process controller and safety limit in one package

- Meets UL® 1998 and CE 60730 requirements
- Eliminates the need for a thermal fuse on a heater
- Eliminates replacement of heater when fuse fails

#### Optional display/communications module

- Allows easy upgrade on to base device
- Offer low cost field upgrade
- Provide easy, snap-on installation

#### Accurate and flexible temperature process controller

- Replaces problematic bi-metal thermostats with accurate electronic temperature process controller
- Allows easy change of process parameters

#### Ambient operating temperature range 32 to 158°F (0 to 70°C)

- Increases reliability when mounting in harsh temperature environments or in close proximity to heaters

#### Integrated high/low temperature alert signal relay

- Provides dry contact output to activate external alarm or process function
- Signals control status with three integrated LEDs
- Allows a signal of up to two amperes 30V≈(ac/dc), Form A to alert if process temperature is out of range limits



#### Health check diagnostics

- Monitors maximum heater process temperature, maximum ambient temperature and thermocouple operation
- Provides health check signal to inform operator that the process is working correctly

#### Universal power supply

- Allows an input of 85 to 264V~(ac), 50/60Hz
- Provides safe control of up to 2400 watts with 10 amperes switching in both controller and safety limit

#### Can be switched from on-off and PID algorithm

- Increases product life (on-off control is default)
- Offers selectable PID control algorithm for tighter temperature uniformity

#### Universal 1/8 turn mounting bracket

- Allows mounting to most surfaces
- Provides flexible mounting—either horizontally or vertically

### Applications

#### Foodservice equipment

- Warming and serving equipment
- Food holding cabinets

#### Life sciences

- Laboratory equipment
- Medical equipment

#### Packaging

- Heat sealing bars
- Hot glue application equipment

#### Semiconductor processing

- Gas delivery lines

# Thermostats and Accessories

## SERIES EHG SL10

### Technical Information

#### Specifications

##### Operational

- Two, Type K thermocouple inputs - process temperature control and safety limit
- Process temperature output - 10A NO-ARC relay
- Safety limit alarm - 10A relay
- High/low temperature alert - 2A 30V $\approx$ (ac/dc), Form A (single pole, normally open contact)
- On-off temperature controller algorithm, upgraded via communications to PID algorithm (min. cycle time 30 seconds)

##### Standard Molex connectors

- Controllers are integral to the heater and are supplied by Watlow

##### Power

- Isolated universal power supply 85 to 264V $\sim$ (ac), 50/60Hz
- Up to 2400 W with 10A switching capability

##### NO-ARC Relay

- 10A switching
- 4.5 million cycles

##### Environmental

- Ambient operating temperature range 32 to 158°F (0 to 70°C)

##### Agency Approvals

- UL® 1998/ C-UL®
- CE 60730
- Semi-S2

### SERIES EHG Versus Thermostat (typical application)

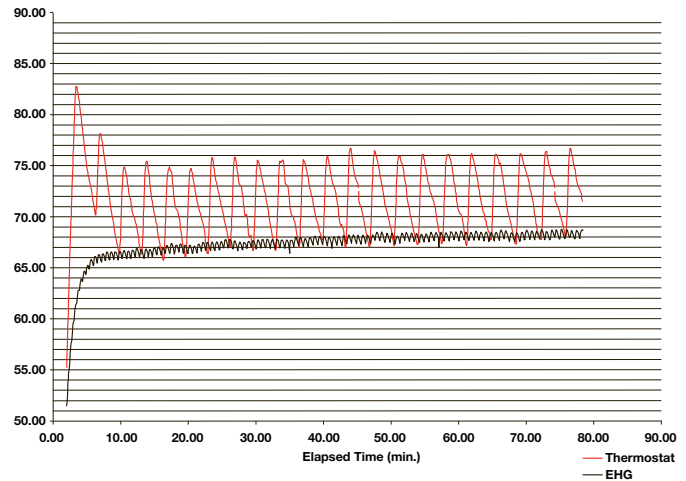

### Dimensions

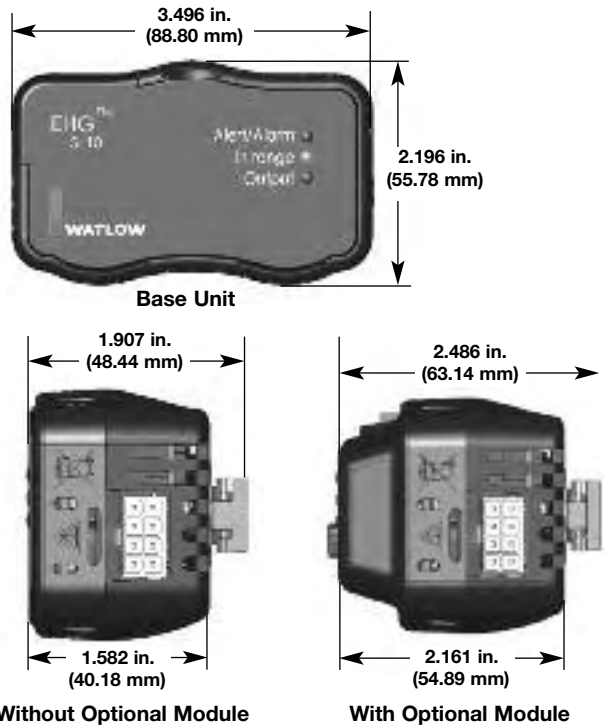

### Switching Device Comparison Chart

	T-Stat	Solid State Relay	Watlow NO-ARC Relay
Amperage at 77°F (25°C)	10A	10A	10A
Amperage at 158°F (70°C)	10A	De-rate significantly and add heat sink and air cooling	10A
Output device life at 10A	Rated 100,000 at 158°F (70°C)	Greater than 10 million cycles at 77°F (25°C)	Greater than 4.5 million cycles at 158°F (70°C)

# Thermostats and Accessories

## SERIES EHG SL10

*Technical Information (Continued)*

### EHG SL10 Software

With the addition of an optional communication module, the EHG SL10 can be managed, monitored and manipulated via software. Change set points, label devices, change tuning parameters, check health status and much more all with the click of a key.



### Reduces System Complexity and Cost

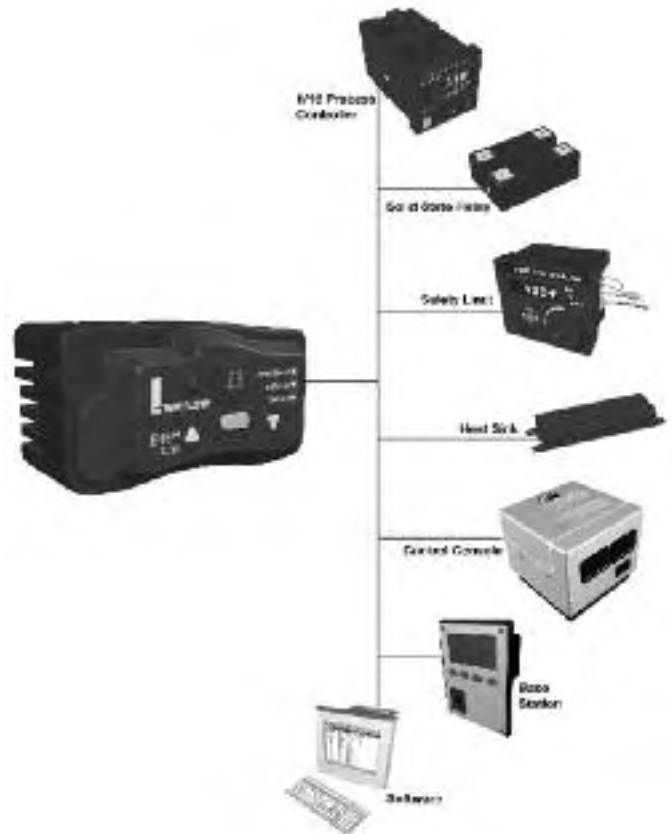

### Mounting Bracket

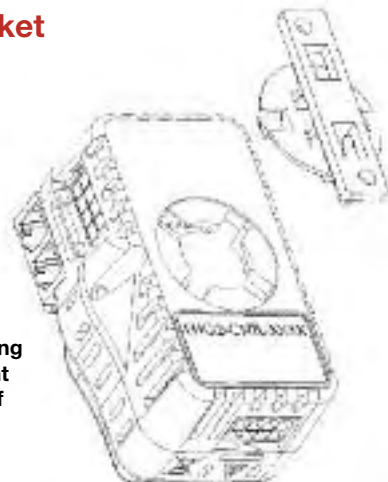

The EHG SL10 mounting bracket lets you mount the controller in any of four angles.



The EHG SL10 can be “daisy-chained” for gas line and other assemblies.





# Thermostats and Accessories

## SERIES EHG SL10

*Technical Information (Continued)*

### Optional Upgrade Modules

These upgrade modules are easy to install because there is no need to reconfigure, rewire or reorder the base unit. No technician is needed for the installation, which creates a seamless, cost-efficient system that can be upgraded.

		Diagnostics Memory Control Parameters	Ability to Change Temperature Parameters	Field Adjustable Set Point	3-Digit 7-Segment LED Display Illuminated	Diagnostic LED's	User Interface Software	Modbus® RTU Communication	RS 485
Base Unit		✓	✓			✓			
Optional Display Module		✓	✓	✓	✓	✓			
Optional Communication Module		✓	✓	✓		✓	✓	✓	✓
Optional Display and Communication Module		✓	✓	✓	✓	✓	✓	✓	✓

# Thermostats and Accessories

## ST10 and ST207

### Temperature Sensors

Watlow® offers several styles of sensors for use with flexible heaters. These sensors are available as preset or adjustable thermostats, thermocouples, thermistors, RTDs or thermal fuses. They can be integrally mounted (encapsulated in silicone rubber) to sense the temperature of either the part or the heater sheath. The thermostats can also be ordered separate from the heater, allowing direct control of your process temperature, if desired.

### Pre-Set Thermostats

Several styles of non-adjustable, pre-set thermostats are available from Watlow. Thermostats separate from the heater are encapsulated in silicone rubber, and are available with standard 12 in. (305 mm) leads unless otherwise specified.

Thermocouples, thermistors, RTDs and thermal fuses are usually mounted to the heater under a vulcanized protective cap of silicone rubber sheath material. This drawing shows a typical mounting style for a thermocouple.

**Note:** Precise part temperature control with preset thermostats requires prototyping and field testing.

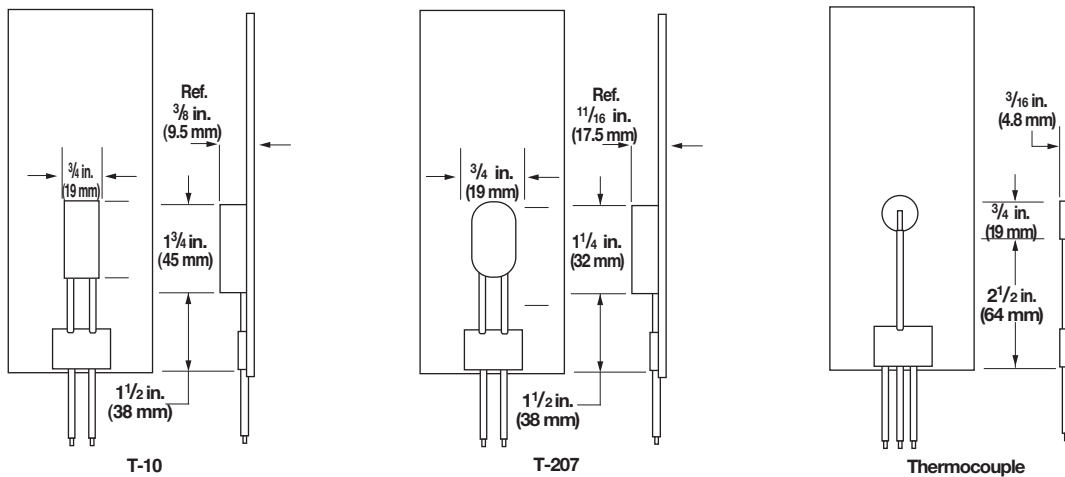
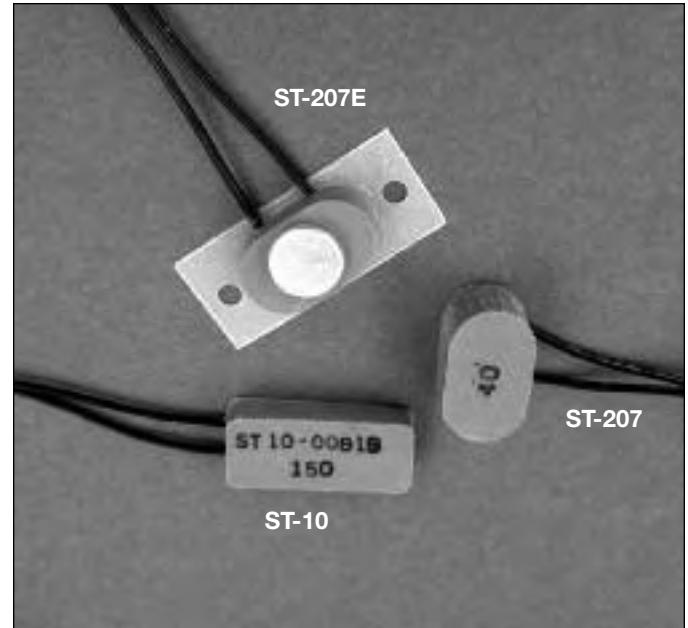

### Pre-Set Thermostats (Non-Adjustable)

Thermostat Model	Maximum Watts	Volts AC	Temperature Settings Available °F (°C)	Agency Approvals		
				UR	cUR	VDE
T-10	600/960	120/240	125-300±10 (50-149±5)	yes	yes	yes
T-207	1500	120/240	40/55±8 (4/13±4.4)	yes	yes	yes
	1500	120/240	60/75±8 (16/24±4.4)	yes	yes	yes
	1500	120/240	95/110±8 (35/43±4.4)	yes	yes	yes
	1500	120/240	145/160±8 (63/71±4.4)	yes	yes	yes

**Notes:**

- When ordering a pre-set thermostat separate from the heater, simply add the prefix **S** to the model number. (Example: ST-10) See next page.
- Snap action preset temperatures on the T-207 are close/open settings.
- T-10 thermostats are manufactured for specific preset temperatures. Available in 25°F increments.
- Other temperature ranges and voltages are available on special order. Minimum quantities apply, contact your Watlow representative before ordering.

# Thermostats and Accessories

## ST10 and ST207

### Temperature Sensors (Continued)

#### Adjustable Thermostats

The B-200 thermostat features a maximum rating of 1500 watts at 120/240V~(ac). The following temperature ranges are available:

- Model B-200-2: 100 to 500°F (40 to 260°C)
- Model B-200-3: 25 to 330°F (-5 to 165°C)

The B-200 thermostat can be integrally mounted to the heater with a bonded protective cap of silicone rubber sheath material.

#### Separate Heater Accessories Available From Stock

#### Pre-Set Thermostats Separate From Heater

These are offered to allow direct control of your process temperature, so you're not limited to controlling only the heater temperature when using stock heaters. Pre-set thermostats are encapsulated in silicone rubber with standard 12 inch leads.

The same temperature ranges, ratings and sizes are available on these thermostats. When ordering, add "S" prefix to the model number to indicate "separate" item. (Examples: ST-10 and ST-207)

Standard leads are 12 in. (305 mm) 18 gauge UL®1180 black leads.

#### Adjustable Thermostats Separate From Heater

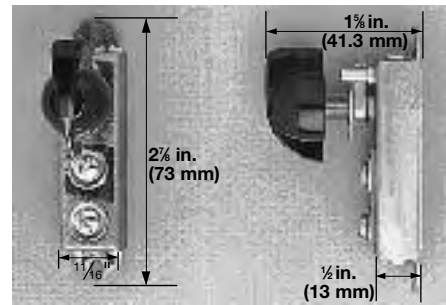

B-200

The Model B-200 adjustable thermostat can be ordered as a separate item. The same model numbers and temperature ranges indicated under *Adjustable Thermostats* are available. When ordering, simply note that you want the **B-200 separate** from the heater.

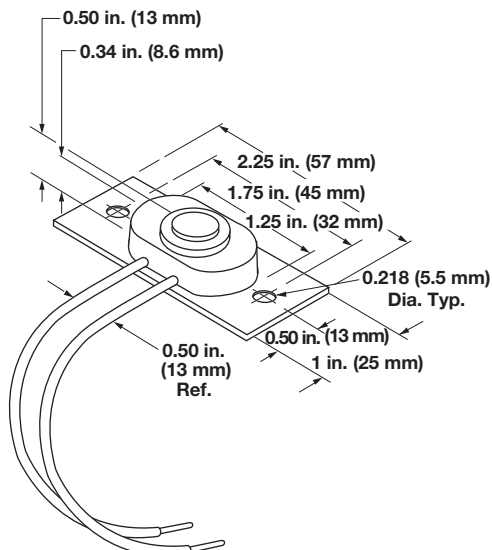

**Note:** For direct control of air temperature as is required in enclosure heating applications, specify thermostat model number ST-207E. This is a modified ST-207 mounted on 1/2 inch thick G-10 circuit board with the thermostat's metal cap exposed to sense air temperature.

# Thermostats and Accessories

## Bulb and Capillary

Thermostats regulate temperature in non-critical applications. They sense temperature, within a preset range and cycle heaters on and off to maintain the set point.

Thermostats may be mounted inside a terminal enclosure or remote mounted (separate from the heater assembly). If using a remote mounted thermostat, be sure to order the sufficient capillary tube length to permit installation.

All Watlow® thermostats are normally closed circuit and either single-pole, single-throw (SPST) or double pole, single-throw (DPST). They can be used with or without an enclosure.

Thermostat selection should be based on temperature range, capillary tube length and sensor bulb size (diameter/length).

## Remote Mount Thermostat Assemblies

Remote mounted thermostat assemblies can be supplied with the following enclosures:

- General purpose (NEMA 1)
- Moisture resistant (NEMA 4)
- Explosion resistant (NEMA 7)
- Explosion/moisture resistant (NEMA 7/4)
- Dust resistant (NEMA 12)

## Pilot Light

An optional pilot light gives visual indication whether the power supplied to the heating element(s) is on or off.

To order, please specify suffix code **PL11**.

## Thermostat Conversion Kits

Kits are available to convert a heater's general purpose (NEMA 1) terminal enclosure to accept either a single- or double-pole thermostat. The kit contains all the necessary parts to change out the existing terminal enclosure cover and mount the thermostat inside.

These are **hardware and wiring kits** only.

**Single-pole conversion kit** covers 1, 1¼, 2 and 2½ inch NPT screw plugs. To order, specify code **K492-000-35-(thermostat type)**.

**Double-pole conversion kit** covers 2 and 2½ inch NPT screw plugs. To order, specify code **K492-000-34-(thermostat type)**.

## Celsius Dial Scale

Thermostats are shipped with Fahrenheit (°F) dial scales. If your application requires a Celsius (°C) scale, order the optional dial face.

To order, specify code **CD**. Scale will match thermostat temperature range.



## Warning

Do not use thermostats for high-limit sheath protection. Thermostats fail in a closed circuit mode and will not cut power to the heaters. Limit control should be provided by an isolated, redundant sensor and control system of the appropriate type, design and installation.

Thermostats are precalibrated at the factory. No adjustment, other than selecting the desired operating temperature, is required. All wiring should be performed by qualified personnel and comply with the National Electrical Code and other applicable state and local codes.

To help assure you select the correct thermostat, as well as install and wire it properly, we have put together a few helpful hints. Schematics are provided for interconnecting thermostats to single- and three-phase heaters.

# Thermostats and Accessories

## Bulb and Capillary

### Technical Information

#### Application Hints

- Locate the thermostat where ambient temperatures do not exceed 150°F (65°C).
- Mount the thermostat in an enclosure that is compatible with the surrounding environment.
- Immerse the entire sensing bulb in the media being heated.
- Make sure the sensing bulb is mounted away from the heating element(s) to negate any undue influence on the sensing bulb's temperature "reading."
- Keep the capillary tube insulated from electrical connections.
- Do not use a thermostat for high-accuracy temperature sensing. Use an appropriate thermocouple, RTD or thermistor and temperature control.
- Do not use thermostats as a primary power switching device. Use a disconnect switch or circuit breaker to cut power when servicing.
- Interconnect the thermostat to the heater only if:
  - The heater has one circuit
  - The heater's ampere draw is lower than the thermostat's rated ampacity at prescribed voltage.
- Interconnect either a single- or double-pole thermostat with a single-phase heater when the supply voltage does not exceed 277V~(ac) for SPST or 480V~(ac) for DPST.
- Only interconnect three-phase delta heaters to DPST thermostats.
- Use a single-pole thermostat for pilot duty where the thermostat is not interconnected with the heater, or heater exceeds the volt/amp rating.

#### Pilot Duty Wiring

##### SPST, 1-phase

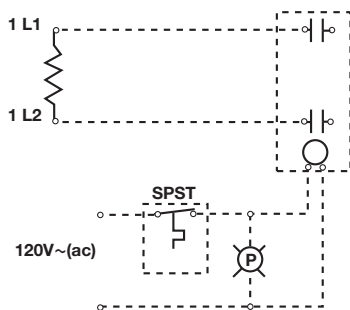

#### Pilot Duty Wiring (Continued)

##### SPST, 3-phase delta

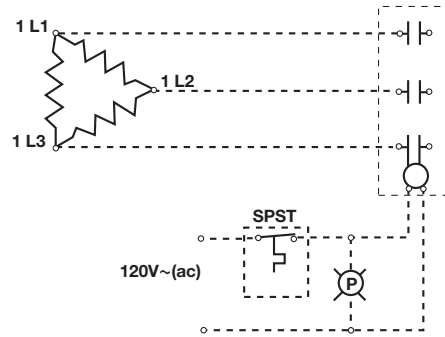

##### SPST, 3-phase wye

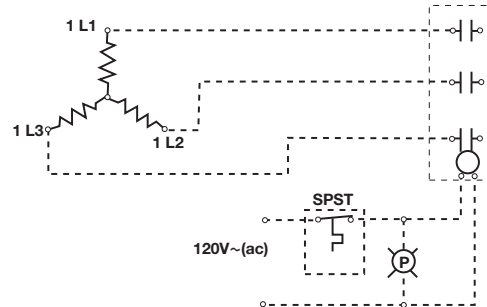

#### Interconnected Wiring

##### SPST, 1-phase

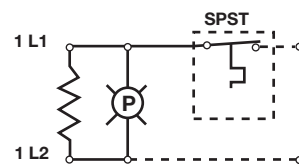

##### DPST, 1-phase

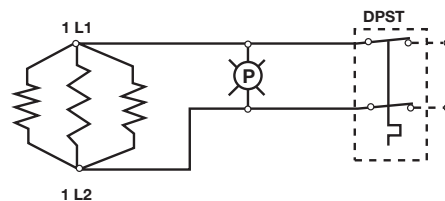

##### DPST, 3-phase delta

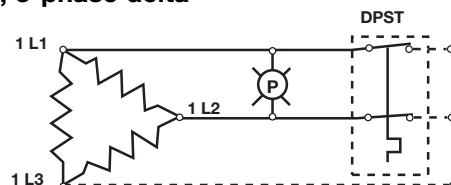

# Thermostats and Accessories

## Bulb and Capillary

Technical Information (Continued)

### Thermostats with Enclosures

#### NEMA 1 Single- and Double-Pole

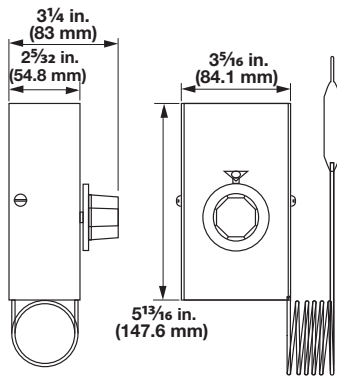

#### NEMA 4 and 12 Double-Pole

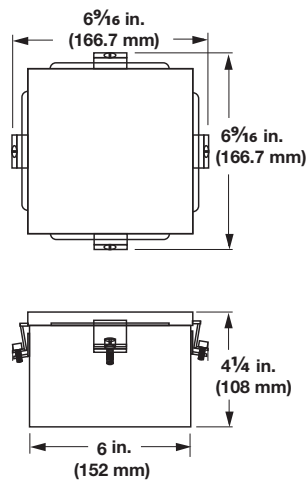

#### NEMA 4 and 12 Single-Pole

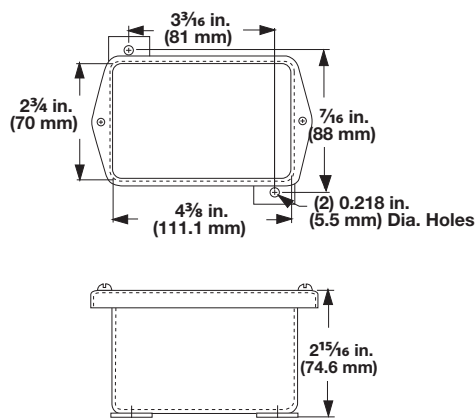

#### NEMA 7 Single-Pole

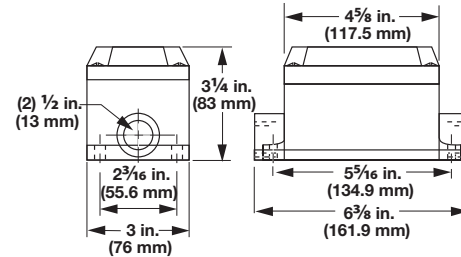

#### NEMA 7 Double-Pole

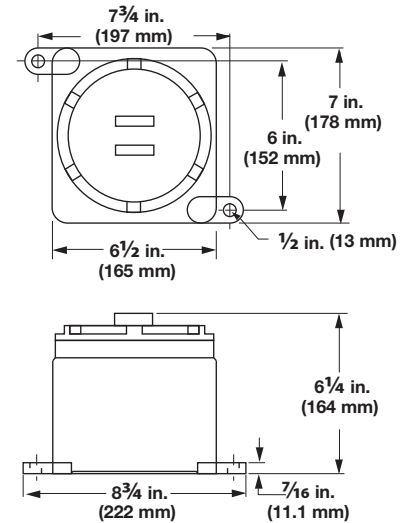

Cross-Reference For Replacement Thermostat	Order With This Number
202-0-21-1 (small knob)	1
202-0-21-2 (small knob)	202-0-21-2MB
202-0-21-4	2
202-0-21-5	2A
202-0-21-3	3
202-0-21-8 (small knob)	202-0-21-8M
202-0-21-6	3A
202-0-4-2	4
202-0-4-6	5
202-0-4-17	5A
202-0-4-5	7
202-0-4-16	7A
202-0-3-1	8
202-0-3-3	9
202-0-1-13	10
202-0-29-2	11
202-0-41-2 (small knob)	12A

If you only have the thermostat code number use this cross-reference chart.

# Thermostats and Accessories

## Bulb and Capillary

Technical Information (Continued)



### Thermostat

Control Mode	Type	Temperature Range		Differential °F (°C)	Ampacity @ Line Voltage				Bulb Diameter		Bulb Length		Capillary Length		Terminal Type	Code No.	Est. Net Wt.	
		°F	(°C)		120	240	277	480	in. (mm)	in. (mm)	in. (mm)	in. (mm)	lbs (kg)	(kg)				
On-off Temp Control	Single-Pole	30-110	(0-40)	8 (0)	25	25	22	—	0.250 (6)	4¼ (121)	18 (455)	18 (455)	#12 AWG	<b>1</b>	1	(0.4)		
		30-250	(0-120)	15 (8)	25	25	22	—	0.250 (6)	3¾ (85)	18 (455)	18 (455)		<b>2</b>	1	(0.4)		
	Single-Throw (SPST)	30-250	(0-120)	15 (8)	25	25	22	—	0.250 (6)	3¾ (85)	84 (2135)	84 (2135)	Stranded Leads	<b>2A</b>	1	(0.4)		
		175-550	(80-290)	26 (14)	25	25	22	—	0.250 (6)	3¾ (85)	18 (455)	18 (455)		<b>3</b> ①	1	(0.4)		
		175-550	(80-290)	26 (14)	25	25	22	—	0.250 (6)	2¾ (70)	84 (2135)	84 (2135)		<b>3A</b> ①	1	(0.4)		
		300-700	(150-350)	12 (7)	25	25	—	—	0.375 (10)	3¾ (95)	60 (1525)	60 (1525)		<b>10</b>	1	(0.4)		
	Double-Pole Single-Throw (DPST)	60-160	(15-70)	19 (10)	30	30	30	20	0.250 (6)	4¾ (110)	14 (355)	14 (355)	#8-32	<b>12A</b>	1	(0.4)		
		30-110	(0-40)	12 (7)	30	30	30	10	0.375 (10)	6¼ (160)	36 (915)	36 (915)		Screw Lug	<b>4</b>	2	(0.9)	
		60-250	(15-120)	12 (7)	30	30	30	10	0.375 (10)	4¾ (115)	48 (1220)	48 (1220)	<b>5</b>		2	(0.9)		
		60-250	(15-120)	12 (7)	30	30	30	10	0.250 (6)	6½ (165)	48 (1220)	48 (1220)	<b>5A</b>		2	(0.9)		
100-550		(40-290)	22 (12)	30	30	30	10	0.375 (10)	3¾ (100)	48 (1220)	48 (1220)	<b>7</b>	2		(0.9)			
100-550		(40-290)	22 (12)	30	30	30	10	0.250 (6)	7¼ (179)	48 (1220)	48 (1220)	<b>7A</b>	2		(0.9)			
On-off with	(DPST)	60-250	(15-120)	12 (7)	30	30	30	—	0.250 (6)	6½ (165)	48 (1220)	48 (1220)	#10-32		<b>8</b>	2	(0.9)	
		100-550	(40-290)	22 (12)	30	30	30	—	0.188 (8)	12 (305)	48 (1220)	48 (1220)	Screw Lug	<b>9</b>	2	(0.9)		
Manual Reset	(SPST)	350 ⑨	(180)	—	30	30	20	—	0.250 (6)	3¾ (90)	36 (915)	36 (915)	#10-32 Screw Lug	<b>11</b>	1	(0.4)		

## RAPID SHIP

• RS - Same day shipment up to 15 pieces

① UL® recognized only

⑨ Fixed temperature setting

## Ordering Information

To order, complete the code number to the right with the information below:

Example: **2** **W** **LTB**

Thermostat Code Number \_\_\_\_\_

See stock chart above

Enclosure (Remote Mount Only) \_\_\_\_\_

- S = General purpose (NEMA 1)
- W = Moisture resistant (NEMA 4)
- E = Explosion resistant (NEMA 7)
- E/W = Explosion/moisture resistant (NEMA 7/4)
- D = Dust resistant (NEMA 12)

Options \_\_\_\_\_

- CD = Celsius dial scale
- CB = Chrome bezel
- LTB = Liquid-tight brass fitting (¾ in. - 18 NPT)
- PL11 = Pilot light

# Thermostats and Accessories

## Low Liquid Level Sensors

The Watlow® low liquid level sensor can protect a heating system by sensing when a liquid drops below a predetermined level. This is accomplished by locating the sensor at the minimum desired liquid level in the tank or vessel. The sensor's ASTM Type J thermocouple output can be connected to a variety of controls, alarms and limit protection devices.

To provide an additional margin of protection, the Type J thermocouple makes this low liquid level sensor respond considerably faster than conventional capillary bulb thermostats.

To order, specify code number **BCN5J1SJ**.

### Application Hints

- Only use sensor in **non-flammable** liquids that are compatible with the Incoloy® sheath and 304 stainless steel screw plug.
- Application should tolerate sheath temperature at limit set point.
- The time delay between the low liquid level condition on-set, and the sensor's ability to signal the control device should be adequate to protect the heater(s). See *Installation and Maintenance Instructions* for details.

### Controller Recommendation

- Use Watlow Safety Limit Temperature Controller SERIES 142 (Code number **142A-3605-1300**). This controller features compact sub-panel mounting and is sealed against ambient environment. UL® recognized for limit protection (UL 991, "Tests For Safety-Related Controls Employing Solid State Devices").

### Specifications

**Screw plug:** 1 in. (25 mm) NPT

**Plug material:** 304 stainless steel

**Sheath material:** Incoloy®

**Watt density:** 13 W/in<sup>2</sup> (2 W/cm<sup>2</sup>)

**Watts:** 100

**Volts:** 120V~(ac)

**Immersed length:** 5½ in. (140 mm)

**Thermocouple:** ASTM Type J

**Est. ship. wt.:** 2 lbs (1 kg)

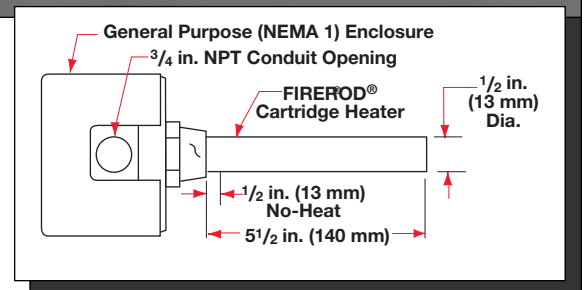

### Availability

**Stock:** Same day shipment

**Modified Stock**<sup>①</sup>: Five to seven working days

**Made-to-Order:** Four to six weeks

Options, complexity and quantity may affect availability and lead times. Contact your Watlow representative.

<sup>①</sup> Stock units with catalog options.

# Thermostats and Accessories

## Protective Wells

Protective wells isolate and protect thermostat bulbs and other temperature sensors (thermocouples, RTDs or thermistors). They allow inserting the sensing element sufficiently into the media being heated without being damaged.

Steel or stainless steel protective wells are available in three lengths. They are supplied with 1/2 inch NPT mounting and 3/8 inch-18 NPT internal thread for mating to a liquid-tight bushing (LTB).

All units are stock. To order, specify the appropriate code number from the stock table.

### Protective Wells

Plug and Thermowell Material	Immersed B Dimension		Code Number	Est. Ship. Wt.	
	in.	(mm)		lb	(kg)
Steel	12	(305)	<b>PWS12</b>	1	(0.5)
	24	(610)	<b>PWS24</b>	2	(1.0)
	36	(915)	<b>PWS36</b>	2	(1.0)
Stainless Steel	12	(305)	<b>PWSS12</b>	1	(0.5)
	24	(610)	<b>PWSS24</b>	2	(1.0)
	36	(915)	<b>PWSS36</b>	2	(1.0)

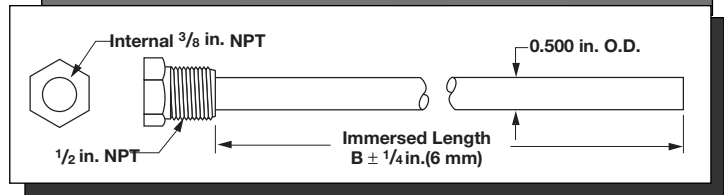
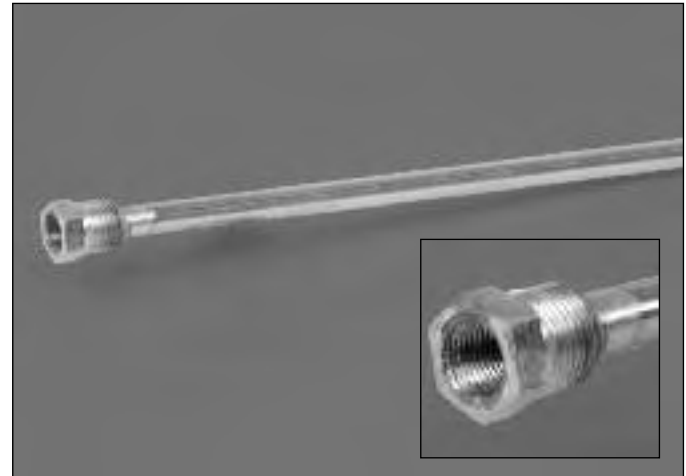

### Availability

**Stock:** Same day shipment

**Modified Stock**<sup>①</sup>: Five to seven working days

**Made-to-Order:** Three weeks

Options, complexity and quantity may affect availability and lead times. Contact your Watlow representative.

<sup>①</sup> Stock units with catalog options.